

AMM - P3 HIGH-PERFORMANCE



MOTORCYCLE IGNITION



CUSTOMER INFORMATION

CONGRATULATIONS!

You've done it.

You just bought the AMM - P3, the world's finest ignition system for all Harley-Davidson® TwinCam- as well as 2004 and up Evolution-Sportster® engines.

Well done. We have put all our experience into this new ignition system in order to give you full control over your motorcycle's performance. The AMM - P3 is able to deliver superior engine performance, better than any other ignition system.

It lets you adjust your ignition timing for your particular engine combination or your special application.

When people come up to compliment you on the style and power of your TwinCam or Sportster®-engine, you can smile knowingly ... and hopefully you'll tell them a little about us.

This ignition system has been designed, tested, improved and again tested and refined to deliver the maximum possible performance. For any Harley-Davidson® TwinCam®-engine, in any situation and with immaculate engine behaviour. Despite its many features, this ignition system has been designed to be very easy to install and to operate.

INTEGRATED SYSTEM

The idea behind this advanced ignition system is to combine a high-performance 16MHz ignition computer, an ignition power amplifier and supplementary features as adjustable advance curves into a compact unit. A total system that outperforms any stock or aftermarket ignition. The whole miniature electronic assembly is contained into a small steel / aluminium housing, that can be mounted near the stock ignition coil or at any location in your motorcycle. Just connect the Crank-Sensor, the coil, ground and ignition plus and you have done the job. No further adjustments required.

The factory MAP- and cam- sensors are not required, when using the AMM - P3 ignition system.

COMPLETELY ADJUSTABLE ADVANCE CURVE

The high resolution advance curves of the AMM - P3 ignition can be adjusted anywhere and anytime within a fraction of a second with the 3 control knobs. No computer required. The P3 lets you individually adjust the maximum advance timing, rate of advance timing, & rpm limit. This unique feature enables you to tune your Harley®-Engine within seconds or to change „The Character of Your Engine“. In some cases a change of the advance-curve has such dramatic effects that you may think, you have bored & stroked your engine. One is sure: YOU will discover how great Your Harley®-Engine CAN perform.

Whether you have installed drag-, sport- or stock-pipes, bigger cylinders, hotter cams or a compressor or turbo-charger: the AMM - P3 is able to reveal the full potential of your engine, while maintaining rock solid reliability, ultrafast throttle response and smooth idle at any rpm, you desire.

There is a cool blue LED, that monitors power- and sensor-status.

„SYNCHRO-CONTROL“

The AMM - P3 ignition features the „SYNCHRO-CONTROL“ mode, a development by AMM, capable of automatically optimizing engine-torque through the entire rpm-range. This is done in real-time by elaborate large-scale calculations in the ignition computer. Therefore a rear-cylinder offset adjustment is not necessary.

RIDING PLEASURE

Nothing powers your Harley-Davidson® TwinCam® engine better than the AMM - P3. Period.
Install Your AMM - P3, start your engine and go for a ride.

If you have any questions or need more information about our products don't hesitate to contact the next AMM-dealer AMM directly.

Additional information is also available on our web-site: www.amm.haan.de



DIPL.-ING. CHARLES ALTMANN · ERLENSTRASSE 15 · 42697 SOLINGEN · GERMANY · PHONE +49-212-2337039

AMM reserves the right to make changes without further notice to any products herein to improve reliability, function or design.

Disclaimer: All words marked with ® are used as a reference only, and belong to the Harley-Davidson company, which is in no way affiliated with AMM.

ALTMANN MICRO MACHINES

GLOBAL WARRANTY AND PROPRIETARY RIGHTS STATEMENT

Limited Warranty:

ALTMANN MICRO MACHINES („AMM“) warrants to you as an end-user purchaser AMM Hardware Products against defects in material and workmanship for a period of FIVE (5) YEARS from the date of original manufacturing, as indicated on the guarantee certificate.

If you discover a defect, AMM will, at its option, repair, replace, or refund the purchase price of this product at no charge to you, provided you return it during the warranty period, with transportation charges prepaid, to AMM Germany. (You can obtain additional information by contacting AMM at the address printed on this certificate.)

To each product returned for warranty service, please attach your name, address, telephone number, error description, and the original guarantee certificate bearing the appropriate AMM serial numbers as proof of original retail purchase.

AMM does not warrant any products that are not AMM products. This warranty does not apply if the product has been damaged by accident, abuse, misuse, or misapplication; if the product has been modified without the permission of AMM; if any AMM serial number has been removed or defaced, or if the original guarantee certificate is lost or not available.

THE WARRANTY AND REMEDIES SET FORTH ABOVE ARE EXCLUSIVE AND IN LIEU OF ALL OTHERS, WHETHER ORAL OR WRITTEN, EXPRESS OR IMPLIED. AMM SPECIFICALLY DISCLAIMS ANY AND ALL IMPLIED WARRANTIES, INCLUDING, WITHOUT LIMITATION, WARRANTIES OF MERCHANTABILITY AND FITNESS FOR A PARTICULAR PURPOSE. No AMM dealer, agent, or employee is authorized to make any modification, extension, or addition to this warranty.

AMM IS NOT RESPONSIBLE FOR SPECIAL, INCIDENTAL, OR CONSEQUENTIAL DAMAGES RESULTING FROM ANY BREACH OF WARRANTY, OR UNDER ANY OTHER LEGAL THEORY, INCLUDING BUT NOT LIMITED TO LOST PROFITS, DOWNTIME, GOODWILL, DAMAGE TO OR REPLACEMENT OF EQUIPMENT AND PROPERTY, AND ANY COSTS OF RECOVERING, REPROGRAMMING, OR REPRODUCING ANY PROGRAM OR DATA STORED IN OR USED WITH AMM PRODUCTS.

AMM'S PRODUCTS ARE NOT DESIGNED, INTENDED OR AUTHORIZED FOR USE AS COMPONENTS IN APPLICATIONS INTENDED TO SUPPORT OR SUSTAIN LIFE, OR FOR ANY OTHER APPLICATION IN WHICH THE FAILURE OF THE PRODUCT COULD CREATE A SITUATION WHERE PERSONAL INJURY OR DEATH MAY OCCUR. SHOULD CUSTOMER PURCHASE OR USE THE PRODUCTS FOR ANY SUCH UNINTENDED OR UNAUTHORIZED APPLICATION, CUSTOMER SHALL INDEMNIFY AND HOLD AMM AND THEIR RESPECTIVE OFFICERS, EMPLOYEES AND DISTRIBUTORS HARMLESS AGAINST ALL CLAIMS, COSTS DAMAGES, AND EXPENSES, AND REASONABLE ATTORNEY FEES ARISING OUT OF, DIRECTLY OR INDIRECTLY, ANY CLAIM OF PERSONAL INJURY OR DEATH ASSOCIATED WITH SUCH UNINTENDED OR UNAUTHORIZED USE, EVEN IF SUCH CLAIM ALLEGES THAT AMM WAS NEGLIGENT REGARDING THE DESIGN OR MANUFACTURE OF THE PART.

Proprietary Rights Statement

All AMM Software Products (whether embedded in ROM's or other hardware or contained on diskettes or other media) including all related manuals and documentations (collectively „AMM Software“) are proprietary to AMM, copyrighted with all rights reserved, and licenced to you. All AMM Software is delivered subject to the terms of the related license agreement.

With regard to any AMM Software contained in purchased hardware products, the AMM Software may only be used with the related hardware products. No AMM Software may be (i) separated from any hardware products as shipped by AMM, or (ii) distributed, copied, translated, disassembled, decompiled, reverse engineered, merged or combined with other software, adapted, varied or modified.

All AMM manuals and documentation of any kind are proprietary to AMM and are copyrighted with all rights reserved.

This Proprietary Rights Statement shall be interpreted in conjunction with any applicable AMM Software License Agreement, but in the event of any conflict, the latter terms and conditions shall prevail.

AMM - P3 HIGH-PERFORMANCE MOTORCYCLE IGNITION

SYSTEM OPERATION INSTRUCTIONS

Well, there's not much to know about the P3. After installation, you just have to find the proper advance-curve.

The green knob sets the max. advance:

- 0 -> 26,0° for open pipes, very high comp., turbo
- 1 -> 30,0° for open pipes, high compression
- 2 -> 34,0° for stock or supertrapp-style exhaust
- 3 -> 38,0° for lightweight bikes with stock or supertr. exh.

The yellow knob adjusts the rise of the curve.

- 0 -> very slow rise -> for turbo or very high compression
- 1 -> slow rise -> for open pipes and heavy bike touring
- 2 -> medium rise -> for sport exhaust, supertr. style
- 3 -> fast rise -> for racing applications only

The red knob specifies the rpm-limit.

- 0 -> shutoff above 5750 rpm
- 1 -> shutoff above 6000 rpm
- 2 -> shutoff above 6250 rpm
- 3 -> shutoff above 6500 rpm

Finding the right curve on a dyno:

With full throttle, adjust green knob, while monitoring engine power. The lowest setting with max. power is the right advance setting.

Record one dyno run from 1000 to 4000 rpm for every setting of the yellow knob. Check the torque values between 1000..4000 rpm. Adjust the yellow knob for best torque curve.

Finding the right curve just by riding the bike:

With stock or sport (supertrapp, Vance & Hines, etc) exhaust, set both knobs: advance (green) and rise (yellow) to 2 -> 34° max. advance, medium rise.

With open pipes or higher compression set advance & rise to 1 -> 30° max advance, slow rise.

Try out and concentrate on the difference between these two settings, in order to get a feel for it. Then you may play with different settings.

Rules of Thumb:

The louder the exhaust, the lower the max. advance should be. If exhaust is silent, you can have more advance. The higher the compression, the lower the max. advance must be.

If you can't get it running, we will assist you. Just drop us a line: amm@haan.de

What you should not do to your AMM - P3:

Do not open your AMM - P3. If you open the case, you will lose the warranty.

When cleaning your motorcycle, do not aim with a high pressure water-stream at your AMM - P3.

Each adjusting knob of your P3 has 4 switch positions that are indicated by a number in the small knob-window. Do not leave any one of the 3 knobs between two positions, since you may weaken the locking spring inside the switch mechanism.

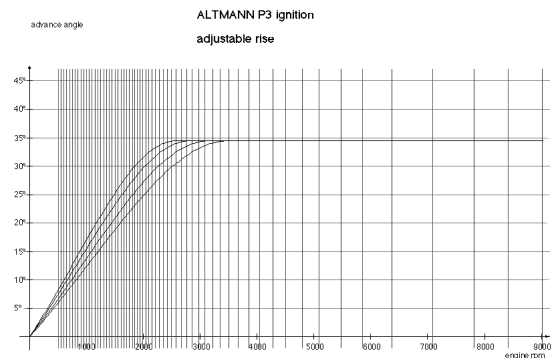
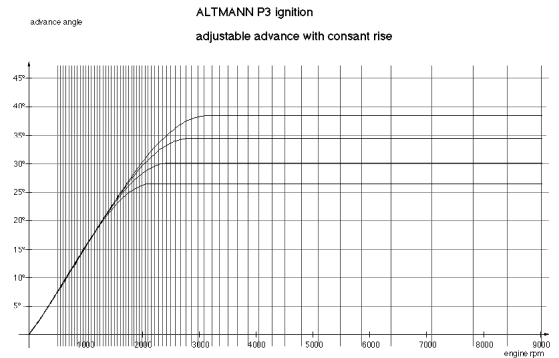

AMM - P3 HIGH-PERFORMANCE MOTORCYCLE IGNITION

INSTALLATION INSTRUCTIONS

Checklist:

- If you have a heart-disease, let someone else do the job!
- The AMM - P3 system is no toy-stuff. If you don't want to be electrocuted, turn ignition OFF and disconnect the ignition coil (the coil connector). It is also good practice to disconnect the battery plus terminal.
- I have designed the AMM - P3 as a powerful tool for the experienced rider. It will give you flawless engine performance, but it is not checked to comply with any law or regulation in any state or country. If you use it, you do it on your own risk and responsibility. If in doubt, ask the police or your local dealer.
- The AMM - P3 lets you adjust the advance curve over a broad range. Please read the operation instructions for finding the appropriate advance setting for your bike. Using a completely wrong curve will give bad engine performance and should be avoided.

Installation:

1) What bike do you have, and which location do you want the AMM - P3 to install? The AMM - P3 comes with a coil-mount. There is a coil mount for Dyna-glide® models (below the coil) and custom applications and a curved coil mount for Softail® models (above the coil). You can also place your AMM - P3 under the seat, behind the side-box (dyna's) or anywhere you want, as long as you do not choose a place with excessive heat or water exposition.

Note: On EFI equipped motorcycles the injection body must be upgraded by a high-quality carburetor (i.e. Keihin, Mikuni, S&S, etc). A high performance carburetor system in conjunction with the AMM-P3 ignition will improve power, torque, engine response, smoothness, flexibility, operating security and gas consumption of your TwinCam® engine.

2) Now that you have found the desired mounting location for your AMM - P3, we will study the diagrams. I have supplied a system overview diagram. Looks easy, here we go...

3) Let's do the connections. As I am a lazy writer, I have also made a drawing for it. Take a look at the 5-step connection sequence drawing. As you have already decided where to install your AMM - P3, I will not talk about cable lengths, when I say you must cut this or that cable. You must find out for yourself (you've been warned). When I say „connect to the P3“, I mean that you have to isolate the end of the wire, and crimp a cable end sleeve (supplied) on it, in order to have a trouble free connection that will last for years; and then screw the prepared end of the wire into the P3 connector.

Okay, take the coil cable that comes from the bike electrics and cut it to „desired length“, in order to connect it to the P3 as indicated on the connection sequence drawing step 1&2. If you made it too short, you have to get yourself a new coil connector (with crimping terminals) and make yourself a new coil cable. So please check before you cut.

Connect as indicated (check the colors) to the P3's connector. Great Job.

Now the +12Volt line. This is the w/bk wire that comes out of the other end of the coil cable. Connect it to the P3 as indicated on step 3. Tape the remaining two wires as shown. That was half the job. Great.

We also need a ground connection, step 4. This must be a good one, because the P3 is a high-performance ignition and is able to sink about 20 Amperes. Use the supplied black wire to make the ground connection. Screw it on the frame and check, that it really has ground. Bad ground can be a source of troublesome symptoms, that will make you control any part of the motorcycle, but not the ground connection. Sorry for being a pedant. I just want you to be happy in the end.

If you have a tachometer installed, you can connect it directly to the tach-output of the AMM-P3 as shown in step 4 1/2. The tach-output of the AMM-P3 works with OEM- and many aftermarket tachometers.

The last task is connecting the Crank-Sensor to the P3. Just disconnect the sensor-cable from the stock module and connect to the P3 as shown in step 5.

Turn the P3 upside down (with plugged connector) and check if everything is connected according to the sticker. That was it.

Connect the coil-connector and ignition wires. Mount the P3, the coil and coil-housing. Reconnect Battery.

4) Turn ignition ON... The blue LED lights up... You smile... Start the engine and go for a ride...

5) It is possible, that the Check-Engine-Lamp inside the speedometer lights up, during engine run. This is because the stock electronic module „thinks“, that the ignition coil is not okay, since it is disconnected from the stock module. No problem. Just disconnect the Check-Engine-Lamp from the stock module. You don't need it anymore. The blue LED of the AMM - P3 is your new check-lamp. If it lights up, power is there. If it blinks during engine rotation, the crank-sensor is also okay. And as the bike runs great now, everything is just fine.

AMM - P3 IGNITION SYSTEM OVERVIEW

Connection Diagram for coil #31655-99 (carbureted Twincam and '04-up Sportster engines)



DIPL.-ING. CHARLES ALTMANN
 ERLENSTR. 15
 42697 SOLINGEN • GERMANY
 TEL FAX: +49(0) 212 - 233 - 7039

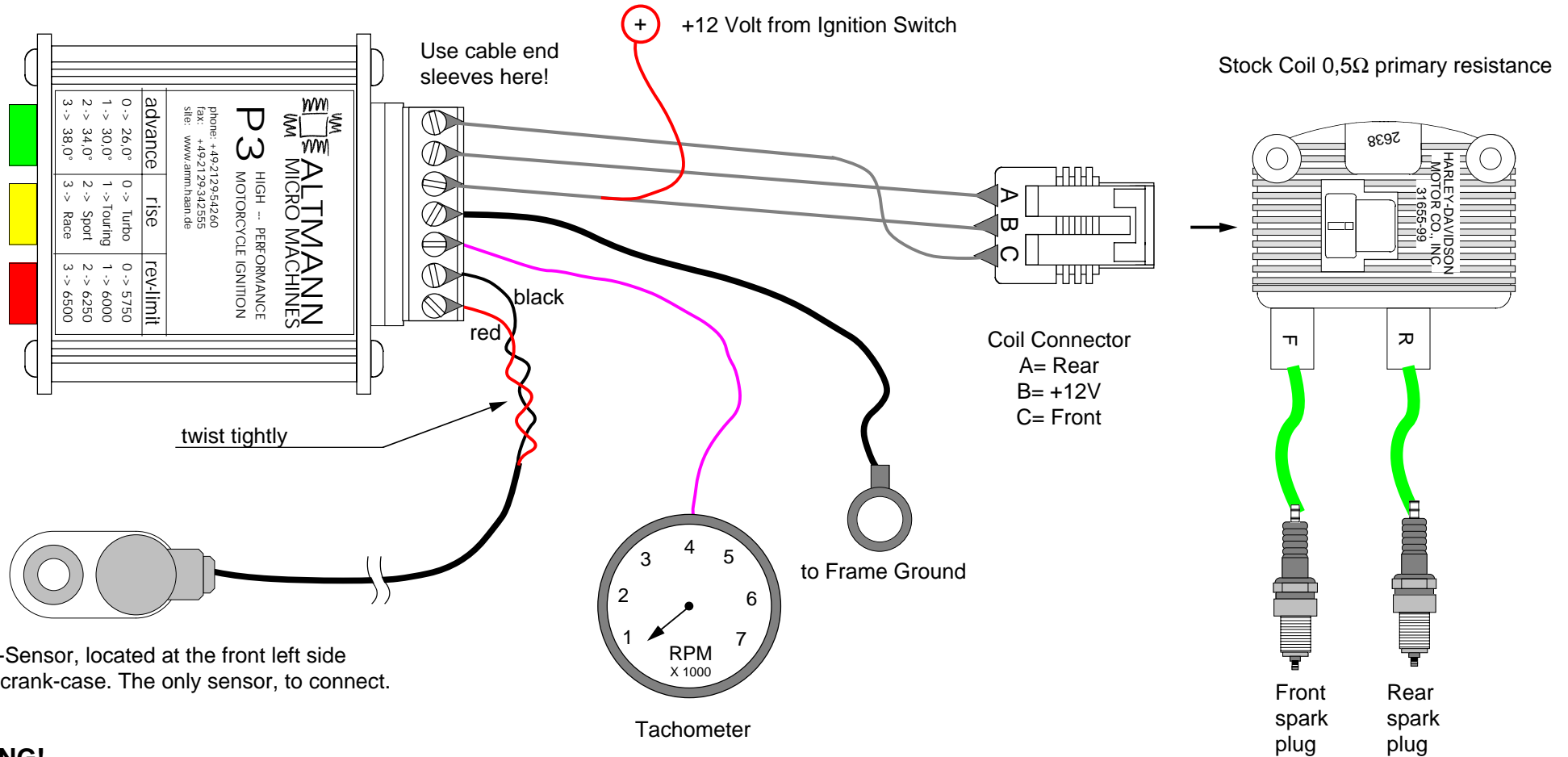

Crank-Sensor, located at the front left side of the crank-case. The only sensor, to connect.

WARNING!

Persons with heart diseases must not install or maintenance this ignition system!

Do not overtighten terminal screws. Please take care, that there are no short circuits between the cables.

During installation keep the ignition coil disconnected from the P3 ignition in order to prevent dangerous voltages. Never use this ignition system without ignition cables and spark-plugs properly connected! This diagram is for coil OEM 31655-99. If you use a different ignition coil, please refer to the corresponding diagram.

AMM - P3 IGNITION SYSTEM OVERVIEW EFI TO CARBURETOR UPGRADE

Connection Diagram for coils #31743-01 and #31656-07 (injected Twincam and Sportster engines)



DIPL.-ING. CHARLES ALTMANN
ERLENSTR. 15
42697 SOLINGEN • GERMANY
TEL FAX: +49(0) 212 - 233 - 7039

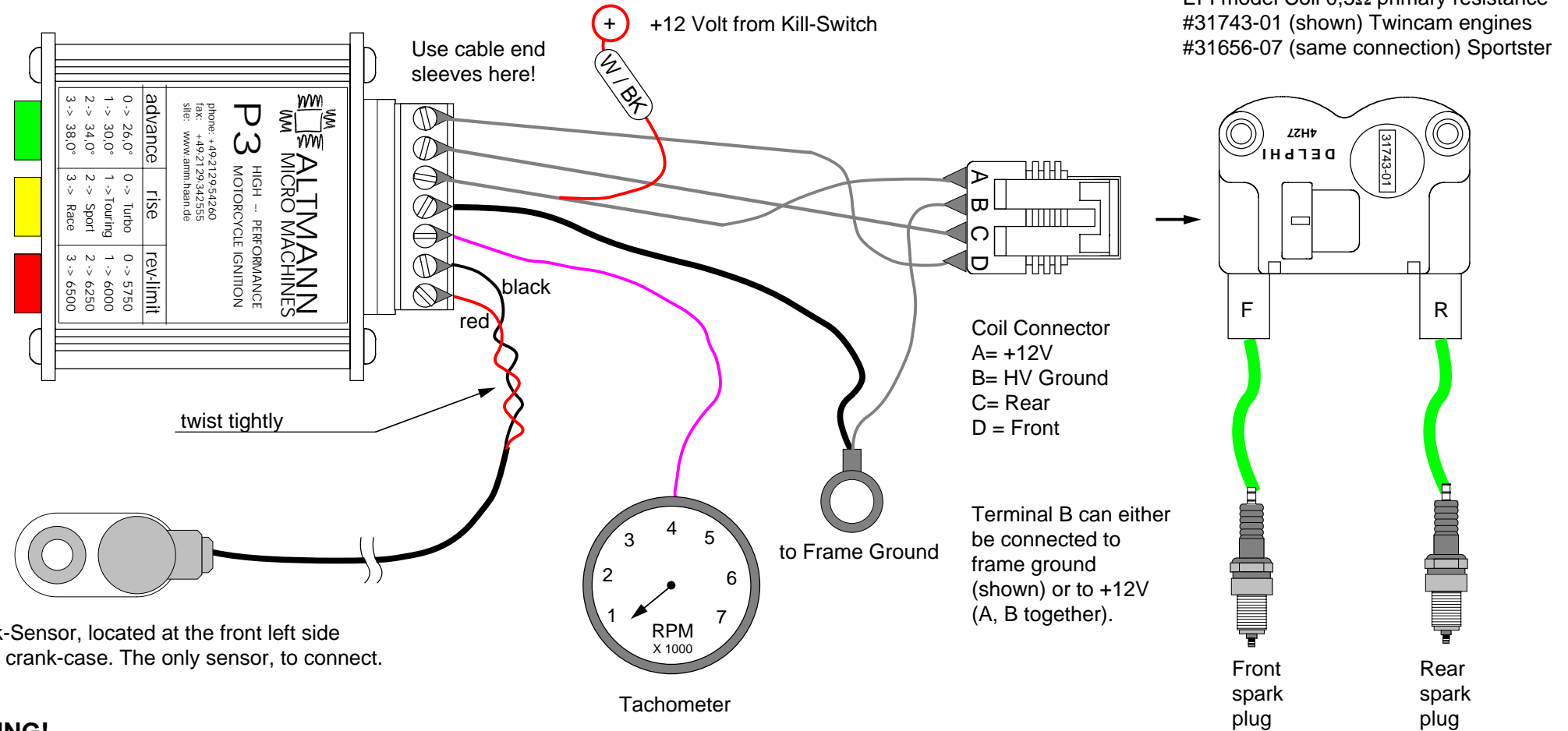

ALTMANN MICRO MACHINES HIGH PERFORMANCE MOTORCYCLE IGNITION	
P3	
phone: +4921293425260 fax: +492129342555 site: www.amm.haan.de	
advance	0 -> 26,0°
	1 -> 30,0°
	2 -> 34,0°
	3 -> 38,0°
rise	0 -> Turbo
	1 -> Touring
	2 -> Sport
	3 -> Race
rev-limit	0 -> 5750
	1 -> 6000
	2 -> 6250
	3 -> 6500

Crank-Sensor, located at the front left side of the crank-case. The only sensor, to connect.

WARNING!

Persons with heart diseases must not install or maintenance this ignition system!

Do not overtighten terminal screws. Please take care, that there are no short circuits between the cables.

During installation keep the ignition coil disconnected from the P3 ignition in order to prevent dangerous voltages. Never use this ignition system without ignition cables and spark-plugs properly connected! This diagram is for EFI coils #31743-01 and #31656-07. If you use a different ignition coil, please refer to the corresponding diagram.